



A Holistic Approach to Reduce Ship Operation Costs

Volker Höppner

FutureShip GmbH, Hamburg/Germany

1 Introduction

For the past decade, the maritime market has been characterized by ship owners having to accept ship yards pursuing minimum building costs, rather than minimum life-cycle costs. In addition, ships have been designed for much lower fuel costs. However, mid-term and long-term fuel prices are expected to range between 500 \$/t and 1000 \$/t and IMO (International Maritime Organization) is expected to pass regulations on CO₂ (carbon-dioxide) ship emissions after 2012, adding pressure to reduce fuel consumptions. Ship operators will put pressure on ship owners to obtain fuel efficient ships. These in turn will put pressure on ship yards to supply fuel sufficient ships. As a result, we expect to see a paradigm shift in designs and refits to reduce fuel consumption in ships.

There are any many ways to reduce fuel consumption.

- reduce required power for propulsion
- reduce required power for equipment on board
- use fuel energy more efficiently for propulsion and on-board equipment

2 Reduce required power for propulsion

We may use traditional hydrodynamic approaches to decompose the power requirements into resistance and propulsion aspects. While propulsor and ship hull should be regarded as systems, the structure may help to understand where savings may be (largely) cumulative and where different devices work on the same energy loss and are thus mutually excluding alternative.

2.1. Reduce resistance

There are many ways to reduce the resistance of a ship. On the most global level, there are two (almost trivial) options:

- Reduce ship size: The lightship weight may be reduced for example by (expensive) lightweight materials, more sophisticated structural design involving possibly formal optimization and reducing the ship length. None of these options is straightforward. The ship length should consider hydrodynamic aspect as well as production and weight aspects.
- Reduce speed: Speed reduction is a very effective way to reduce fuel consumption and emission. Slow steaming reduces in itself fuel consumption significantly. However, the ship is then operated in off-design, thus sub-optimal condition. This offers assorted potential improvements to reduce the fuel consumption further: electronically controlled main engines allowed better efficiencies at slow steaming and reduce also lubrication oil consumption; controllable pitch propellers allow better propeller efficiency over a wider range of rpm; adapted new bulbous bows may reduce wave resistance considerably. On the other hand, waste heat from exhausts and cooling water is considerably reduced and may require reconfiguration of auxiliary engine systems for slow steaming. In sum, a supporting engineering analysis is recommended when deciding on slow steaming for a longer time.

The largest levers in ship design lie in the proper selection of main dimensions and the ship lines. Ship model basins should be consulted to assess the impact of main dimensions based on their experience and data bases. On a more detailed level, for a given speed and ship weight, all components of the ship resistance, Bertram (2000a), may offer fuel saving potential:

- Frictional resistance of bare hull: The frictional resistance (for given speed) depends mainly on the wetted surface (main dimensions and trim) and the surface roughness of the hull (average hull roughness of coating, added roughness due to fouling). Ships with severe fouling may require twice the power as with a smooth surface.

Silicone-based coatings create non-stick surfaces similar to those known in Teflon coated pans. In addition to preventing marine fouling effectively, these smooth surfaces may result in additional fuel savings. Figures of up to 6% are quoted by shipping companies. As a rule of thumb, every 25 μm of hull roughness corresponds to 0.7-1% of propulsion power,

- Wave resistance of bare hull: For given main dimensions, wave resistance offers large design potential. Moderate changes in lines can result in considerable changes of wave resistance. As the length of the created waves depends quadratically on speed, the interaction of bulbous bow and forebody of the ship changes with speed. Thus a bulbous bow changes effectiveness with speed. Bulbous bows should be designed based on CFD (computational fluid dynamics), but in most cases fast codes based on simplified potential flow models suffice, Bertram (2000a). A formal optimization is recommended as this may offer 1-2% improvement even on hulls that are deemed already 'optimized' in limited form variations with CFD and model tests in model basins, Fig.1, Abt and Harries (2007). This option is particularly attractive for new designs where the ship owner can and should specify that such an optimization is performed. For existing ships, refits of bulbous bows may have payback times of less than a year, but it is frequently problematic to obtain original hull descriptions..
- Residual resistance of bare hull (mainly due to flow separation): Flow separation occurs when the velocity gradients become too large in a flow. Large curvature in flow direction should then be avoided. Flow separation in the aftbody is delayed by the flow acceleration due to the propeller and different in model scale and full scale. CFD simulations may help in finding suitable compromises between hydrodynamic and other design aspects.
- Resistance of appendages: Appendages contribute disproportionately to the resistance of a ship. CFD simulations can determine proper alignment of appendages.
- Rudder resistance: Rudders offer an often underestimated potential for fuel savings. Improving the profile or changing to a highly efficient flap rudder allows reducing rudder size, thus weight and resistance. Due to the rotational component of the propeller, conventional straight rudders at zero rudder angle encounter oblique flow angles to one side at the upper part and to the other side in the lower part. This creates opposing lift forces which cancel each other, but the associated induced drag forces add. By twisting the rudder these unnecessary drag forces can be reduced. Compared to a conventional semi-balanced rudder, a twisted rudder with Costa bulb may have 4% lower power consumption, Hollenbach and Friesch (2007). In theory, the gap between the hubcap and the forward part of the bulb should be as small as possible.
- Added resistance due to seaway: Intelligent routing (i.e. optimization of a ship's course and speed) may reduce the average added resistance in seaways. For example, the Ship Routing Assistance system, Rathje and Beiersdorf (2005), was originally developed to avoid problems with slamming and parametric roll, but may also be used for fuel-optimal routing.

For each draft and speed, there is a fuel-optimum trim. For ships with large transom sterns and bulbous bows, the power requirements for the best and worst trim may differ by more than 10%, Mewis and Hollenbach (2007). Systematic model tests or CFD simulations are recommended to assess the best trim and the effect of different trim conditions.

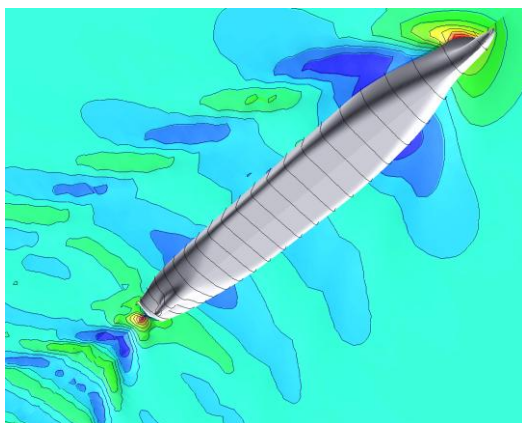

Figure 1. Bulb optimization by CFD, source: www.fsopt.com

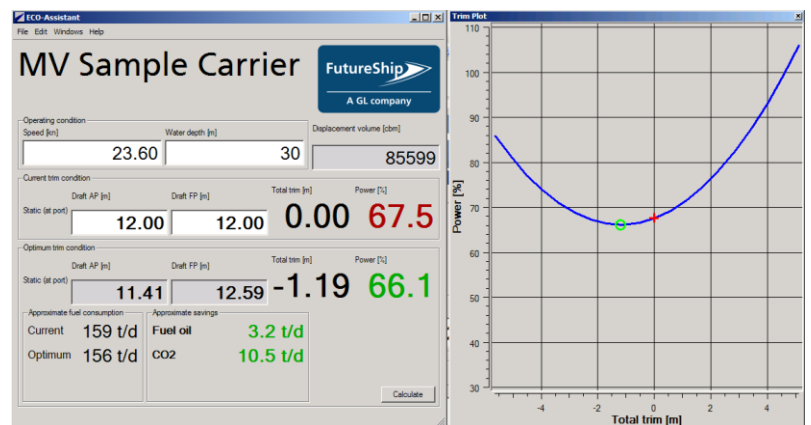

Figure 2. ECO Assistant provides the right trim for any operational profile

2.2. Improve propulsion

The propeller transforms the power delivered from the main engine via the shaft into a thrust power to propel the ship. Typically, only 2/3 of the delivered power is converted into thrust power. A special committee of the *ITTC (1999)* discussed extensively assorted unconventional options to improve propulsion of ships and the associated problems in model tests. In short, model tests for these devices suffer from scaling errors, making quantification of savings for the full-scale ship at least doubtful.

- Operate propeller in optimum efficiency point: The propeller efficiency depends among others on rpm and pitch. Fixed pitch propellers are cheaper and have for a given operating point a better efficiency than controllable pitch propellers (CPPs). They may be replaced if the operator decides to operate the ship long-term at lower speeds. CPPs can adapt its pitch and thus offer advantages for ships operating over wider ranges of operational points. Several retrofit projects have been reported, with savings up to 17% quoted due to new blades on CPPs,
- Operate propeller in better wake: The propeller operates in an inhomogeneous wake behind the ship. This induces pressure fluctuations on the propeller and the ship hull above the propeller, which in turn excite vibrations. The magnitude of these vibrations poses more or less restrictive constraints for the propeller design. A more homogeneous wake translates then into potentially better propeller efficiency, for example by a larger propeller diameter or larger blade loading on the outer radii. For new designs, wake equalizing devices like Schneekluth nozzles (a.k.a. wake equalizing ducts (WED)), Grothues spoilers, vortex generators, Schneekluth and Bertram (1998), may therefore improve propulsion and save fuel. For existing ships, despite several refits more recent independent analyses shed doubts concerning the effectiveness of WEDs, Ok (2005).“

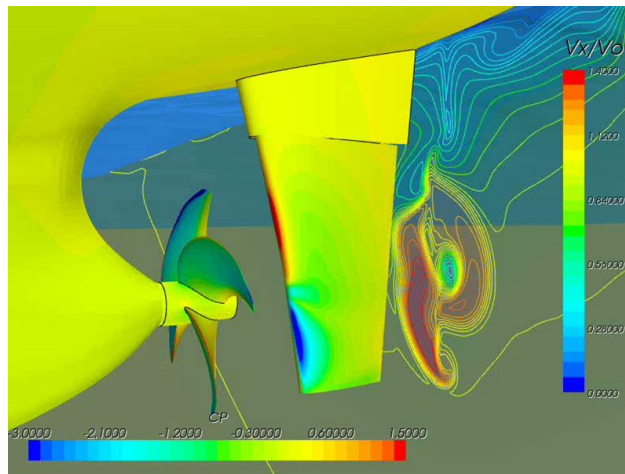

Figure 3. Improving propulsion: CLT propeller (left), PBCF (center), Grim vane wheel (right)

2.3. Other aspects

Resistance and propulsion and main engine interact. Partial improvements of individual components as possible as discussed so far, but the system analyses considering the interaction of the components offers additional saving potential.

Ships are frequently hydrodynamically tuned for a design speed, but later operated most of the time at lower speeds, even when they are not “slow-steaming”. If designed for a more realistic mix of operational speeds, ships are estimated to exploit further fuel saving potential. Similarly, an even speed profile in operation saves fuel. This is largely a question of awareness. Fuel monitoring systems have proven to be effective in instigating more balanced ship operation with fuel (and emission) savings of up to 2%.

3 Reduce required power for equipment on board

There are various options to save power in the assorted energy consuming equipment onboard ships. The saving potential depends on the ship type. Examples are in more efficient electronically controlled pumps, HVAC (heat, ventilation and air conditioning) ventilation systems, and energy saving lighting. Energy-saving lamps not only reduce the energy requirements for lighting, they also reduce the waste heat from the lamps and thus the energy needed by air conditioning systems to cool lighting rooms down again.

Ship engines convert only up to 50% of the fuel energy into propulsive power. Approximately 25% of the fuel energy is lost in the exhaust heat and another 25% in the cooling water. There are various approaches to recuperate some of these energy losses, Hochhaus (2007). Exhaust heat may be used for steam generation or to fuel deep-freeze absorption chillers. Hot coolant may be used to produce fresh water from sea water.

Avoid oversized main engines. Sea margins should be adapted to ship type, ship size and intended operational trade. For example, 7-8% sea margin may suffice for large containerships. The sea margin may be selected based on standard seakeeping analyses or in standard cases also based on experience. The frequently added engine margin may be omitted altogether. Ships are often operated at considerably lower speeds than the design speed, but operators want to keep the capability for occasional high speed. The required margins for such occasional high-speed operator are expensive and may be better covered by falling back on the auxiliary engine power (power take-in (PTI) via shaft generator) on the rare

occasion when high speed is needed. Detailed engineering analyses can be used to assess feasibility and cost aspects of alternative configurations, Fig.5. For slow-steaming ships with controllable pitch propeller, it is better to reduce the brake mean effective pressure than the rpm. If the ship shall be operated at lower speeds for a longer period the engine may be adapted to the mean effective pressure by changing the fuel injection system or installing an exhaust turbo-charger. Intelligent monitoring and simulation software can combine engine supplier data and standard onboard monitoring data for a given operational profile to determine optimum combinations of propeller pitch and rpm.

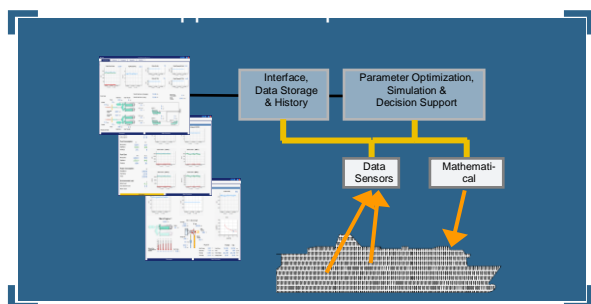

Figure 4. A decision support systems makes everybody even unskilled staff capable to save fuel

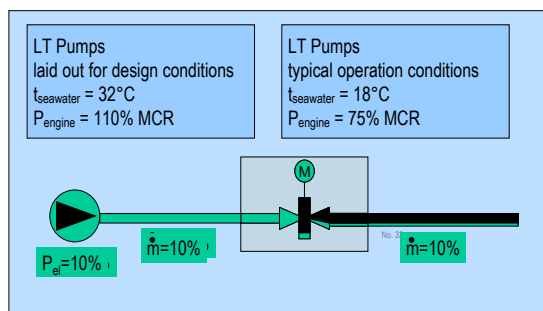

Figure 5. standard controlled rotating equipment systems spoils the majority the electrical power using a valve

Avoid oversized auxiliary engines. Better overall energy management systems may balance the energy demand of the consumers on board reducing peak demands allowing in turn a reduction of the generator capacity. This in turn reduces the weight of the ship. Simulations of the overall machinery system are able to predict fuel consumptions for provided energy consumer profile, Fig.5. These simulations allow assessment of alternatives and ultimately better balanced energy profiles.

4 Conclusion

There are many technical levers to save fuel and thus emissions for ships. Unfortunately, there is large scatter in saving potential and quoted saving potential is unreliable. Manufacturers frequently quote best cases and sometimes extrapolate erroneously results from model tests to full scale ships. Despite these uncertainties, the compiled information may serve for a first assessment on a case by case basis and identification of most promising options. This requires interdisciplinary team work of clients and consulting experts. For a more quantitative assessment, dedicated analyses often based on simulations are required.

Despite these words of caution, there is wide consensus that significant potential for fuel saving exists and service providers like Classification societies can support ship owners and operators in tapping into these potentials.

5 Acknowledgements

Many colleagues at Germanischer Lloyd have supported this paper with their special expertise, namely (in alphabetical order) Bettar El Moctar, Malte Freund, Julia Hoepfner, Volker Bertram, Andreas Junglewitz, Reinhard Krapp, Ralf Plump, Gerd-Michael Würsig.

Volker Höppner graduated from the Technical University Hamburg-Harburg, Institute for Mechanical Marine Engineering. After university he developed software for the evaluation of engine room ventilation and hydrodynamic design before he worked as a design engineer of combustion engines. He held positions as head of departments for design and R&D and was a director for plant engineering and construction. Additionally, he acted as a Country Manager in the former Soviet Union for two companies in the maritime and engineering industry before joining Germanischer Lloyd AG as Managing Director of FutureShip GmbH.